



RAEGuard^S EC
Toxic Gas and Oxygen Transmitter

RAEGuard^S LEL
Combustible Gas Transmitter

RAEGuard^S IR
**Non-Dispersive Infrared (NDIR)
Transmitter**



User's Guide



- READ BEFORE OPERATING -

This manual must be carefully read by all individuals who have or will have the responsibility of using, maintaining, or servicing this product. The product will perform as designed only if it is used, maintained, and serviced in accordance with the manufacturer's instructions. The user should understand how to set the correct parameters and interpret the obtained results.

CAUTION!

To reduce the risk of electric shock, turn the power off before removing the instrument cover. Disconnect the power before removing the sensor module for service. Never operate the instrument when the cover is removed. Remove instrument cover and sensor module only in an area known to be non-hazardous.

WARNING!

The calibration of all newly purchased RAE Systems instruments should be tested by exposing the sensors to known concentration calibration gas before the instrument is used or put into service. For maximum safety, the accuracy of the RAEGuard^S should be checked by exposing the sensor(s) to known concentration calibration gas every three (3) months.

Contents

1. General Information	3
1.1 General Specifications.....	6
RAEGuard ^S EC Specifications	6
RAEGuard ^S IR Specifications.....	7
RAEGuard ^S LEL Specifications	9
2. Operation	10
2.1 Physical Description	11
2.2 Installation and Access Instructions	11
Mounting	12
Instrument Assembly Removal.....	13
Electrical Wiring.....	14
Instrument Assembly Installation.....	15
Earth Grounding Instructions.....	16
2.3 Display And User Interface.....	18
User Interface	18
Magnet Key	18
Using The Magnet Key	19
System Initialization.....	19
Reading Display	20
Alarm Contacts	20
2.4 Calibration	21
Zero Calibration	22
Span Calibration	23
2.5 Advanced Menu (EC & LEL)	25
2.6 Advanced Menu (IR).....	31
2.7 Restoring Default Values (EC & LEL)	31
3. Theory of Operation.....	33
4. Maintenance	35
5. Troubleshooting.....	35
Table A: EC Sensor configuration	37
6. ModBus/RS-485 Information	38

1. General Information

RAEGuard^S EC The RAEGuard^S EC is a fixed electrochemical detector for oxygen and toxic gas (CO, H₂S, SO₂, NO, NO₂, Cl₂, O₂, ClO₂, NH₃, PH₃, HCN and ETO). It operates with voltages from 9 to 36 VDC and provides an analog (4 to 20mA) output signal and digital (RS-485, ModBus) output signal within the corresponding ranges of gas detection. The RAEGuard^S EC uses an interchangeable electrochemical smart sensor, which can be pre-calibrated independently offline. Housed in an explosion-proof enclosure, the RAEGuard^S EC is equipped with a local digital display of the gas concentration and unit of measurement, status LEDs, and function keys for performing calibration.

RAEGuard^S IR The RAEGuard^S IR is fixed non-dispersive infrared (NDIR) detector for hydrocarbon combustible gases, carbon dioxide, and other gases, It operates with voltages from 9 to 36 VDC and provides an analog (4 to 20mA) output signal and digital (RS-485, ModBus) output signal within the corresponding ranges of gas detection of 0 to 100% LEL or 0 to 50,000 ppm CO₂. The RAEGuard^S IR uses a smart NDIR sensor, which can be pre-calibrated independently offline. Housed in an explosion-proof stainless steel enclosure, the RAEGuard^S IR is equipped with a local digital display of the gas concentration, status LEDs, and function keys for performing calibration.

RAEGuard^S LEL The RAEGuard^S LEL is a fixed, highly poison-resistant catalytic bead lower explosion limit (LEL) sensor for combustible gases detection. It operates with voltages from 9 to 36 VDC and provides an analog (4 to 20mA) output signal and digital (RS-485, ModBus) output signal within the corresponding range of 0 to 100% LEL. The RAEGuard^S LEL uses a smart LEL sensor, which can be pre-calibrated independently offline. Housed in an explosion-proof stainless-steel enclosure, the RAEGuard^S LEL is equipped with a local digital display of the gas concentration, status LEDs, and function keys for performing calibration.

RAEGuard^S EC / LEL / IR User's Guide

Key features:

- Interchangeable smart electrochemical sensor that can be calibrated offline
- 4 to 20mA analog output signal.
- RS-485 digital communication in ModBus Protocol
- Explosion-proof stainless-steel enclosure for hazardous environment applications
- Magnetic-key interface eliminates the need to open the explosion-proof housing when adjusting parameters.
- LCD and status/error LEDs
- LED alarms when High or Low alarm point is reached
- Operation at 9 to 36 VDC
- Two dry contacts (<30V, 2A) normally open (or normally closed), one for High and Low alarm, another for Fault alarm

Applications:

- Waste water treatment plants
- Petroleum and natural gas fields
- Marine and offshore oil wells
- Refineries and petrochemical plants
- Solvent recovery systems
- Chemical plants
- Industrial safety
- Sewers and pipelines
- Pulp & paper plants
- Heavy industry
- Power plants
- Steel mills

RAEGuard^S EC / LEL / IR User's Guide

Hazardous Location Classification:

ATEX: II 2G Ex d IIC T6 $-40^{\circ}\text{C} \leq T_{\text{amb}} \leq +60^{\circ}\text{C}$
Complies with EN60079-0 :2004, EN60079-1 :2004

Example Of Name Plate On RAEGuard^S Models:



Notes:

Sensor Name is replaced by the actual sensor name.

FGM-1XXXXS is replaced by model number.

* ≤ 4

** Optional

1.1 General Specifications

RAEGuard^S EC Specifications

Size	7.4" L x 5.9" W x 4.3" H 188mm x 150mm x 109mm
Weight	7.7 lbs 3.5 kg
Detector	Off-line pre-calibrated interchangeable smart electrochemical sensor
Calibration	2-point calibration
Certification	ATEX: II 2G Ex d IIC T6 -40° C ≤ T _{amb} ≤ +60° C Complies with EN60079-0 :2004, EN60079-1 :2004
IP Rating	IP-65
Power	9 to 36VDC, max 40mA at 24V or 1W
Output	4-20mA RS-485, baud-rate 4.8, 9.6 or 19.2kb/sec
Sampling	Internal diffusion
Display	7-segment, 4-digit LCD and 4 color-coded alarm LEDs
User Interface	Magnetically accessed keys for non-intrusive calibration and adjustment
Temperature	-40° C to 60° C
Humidity	0% to 95% relatively humidity (non-condensing)
Pressure	0.9 to 1.1 Atm
Dry contact	Max 30V, 2A
Dry Contacts	30V, 2A, normally open (or normally closed), one for High and Low alarm, another for Fault alarm
Terminal	AWG 24-12
Mounting	2 holes, 5.25" (133mm) from center to center

RAEGuard^S EC / LEL / IR User's Guide

RAEGuard^S IR Specifications

Size	6.6" L x 5.9" W x 4.3" H 168mm x 150mm x 109mm
Weight	7.7 lbs or 3.5 kg
Detector	Protected, Off-line pre-calibrated, interchangeable smart NDIR sensor
Calibration	2 point calibration
Range	CO ₂ : 0 to 50000 ppm CH ₄ : 0 to 100% LEL
Resolution	CO ₂ : When CO ₂ < 10000 ppm, resolution is 1 ppm; When CO ₂ ≥ 10000 ppm, resolution is 1000 ppm CH ₄ : resolution is 1% LEL.
Response Time (T₉₀)	T ₉₀ ≤ 30 seconds
Certification	ATEX: II 2G Ex d IIC T6 -40° C ≤ T _{amb} ≤ +60° C Complies with EN60079-0 :2004, EN60079-1 :2004
IP Rating	IP-65
Power	9 to 36VDC, max 60mA at 24V or 1.5W
Output	4-20mA RS-485 Baud rate: 4.8, 9.6 or 19.2kb/sec
Sampling	Internal diffusion
Display	7-segment, 4-digit LCD 4 color-coded LEDs
User Interface	Magnetically accessed keys for non-intrusive calibration and adjustment
Operating Temperature	CO ₂ : -20° C to +60° C CH ₄ : -40° C to +60° C
Humidity	0 to 95% relative humidity (non-condensing)
Pressure	0.9 to 1.1 Atm
Dry Contacts	30V, 2A, normally open (or normally closed), one for High and Low alarm, another for Fault alarm
Terminal	AWG 24 to 12 (diameter 0.5mm to 2mm)
Mounting	2 holes 5.25" (133mm), from center to center

RAEGuard^S EC / LEL / IR User's Guide

RAEGuard^S IR Default Sensor Settings

Gas	Range	Resolution	Span Gas
Carbon Dioxide (CO ₂)	0 to 50,000 ppm	10 ppm or 1000 ppm	2000 ppm to 10000 ppm
Methane (CH ₄)	0 to 100% LEL	1% LEL	20% LEL to 99% LEL

Note: When CO₂ < 10000 ppm, the LCD displays the reading. When CO₂ ≥ 10000, the LCD displays **X.XE4** (which represents X.X x 10⁴). For example, when the monitor display **1.5E4**, it means 15000 ppm; when the LCD displays **3.6E4**, it means 36000 ppm. The LCD on the RAEGuard^S IR CH₄ displays the %LEL (percentage of LEL) reading. For example, when the LCD displays **25**, it means 25% LEL; when the LCD displays **75**, it means 75% LEL.

RAEGuard^S EC / LEL / IR User's Guide

RAEGuard^S LEL Specifications

Size	6.6" L x 5.9" W x 4.3" H 168mm x 150mm x 109mm
Weight	7.7 lbs or 3.5 kg
Detector	Protected, Off-line pre-calibrated, interchangeable catalytic bead smart LEL sensor
Calibration	2 point calibration
Range	0 to 100% LEL
Resolution	1% LEL
Response Time (T₉₀)	≤15 seconds to 90% of reading to 50% LEL methane
Certification	ATEX: II 2G Ex d IIC T6 -40° C ≤ T _{amb} ≤ +60° C Complies with EN60079-0 :2004, EN60079- 1 :2004
IP Rating	IP-65
Power	9 to 36VDC, max 60mA at 24V or 1.5W
Output	4-20mA RS-485, Baud-rate 4.8, 9.6 or 19.2kb/sec
Sampling	Internal diffusion
Display	7-segment, 4-digit LCD 4 color-coded LEDs
User Interface	Magnetically accessed keys for non- intrusive calibration and adjustment
Operating Temperature	-40° C to +60° C
Humidity	0 to 95% relative humidity (non-condensing)
Pressure	0.9 to 1.1 Atm
Dry Contacts	30V, 2A, normally open (or normally closed), one for High and Low alarm, another for Fault alarm
Terminal	AWG 24 to AWG 12 (diameter 0.5mm to 2mm)
Mounting	2 holes, 5.25" (133mm) from center to center

2. Operation

The calibration of all newly purchased RAE Systems instruments should be tested by exposing the sensor(s) to a known concentration calibration gas before the instrument is used or put into service. For maximum safety, the accuracy of the RAEGuard^S EC should be checked by exposing the sensor(s) to a known concentration calibration gas, after a period of time.

Calibration should be verified daily during the period of initial use in the intended atmosphere to ensure nothing is poisoning the sensor(s). The period of initial use must be of sufficient duration to ensure that the sensors are exposed to all conditions that might have an adverse effect on the sensors.

Verify the calibration with a known concentration test gas before use. This "bump" test is very simple. Recalibrate the unit if readings are off.

Prior to factory shipment, the RAEGuard^S EC is calibrated and tested using span gas. However, the user should calibrate the instrument before the first use. After the unit is installed, run for 24 hours, and calibrated, it is ready for immediate operation. Calibration setting values for EC sensors are shown as Table A (on page 32).

Kit Accessories include: Calibration Adapter, RAEGuard Magnet Key, and User's Guide.

2.1 Physical Description

The design of RAEGuard^S allows it to be easily mounted and interfaced to a fixed-point gas monitoring system. The RAEGuard^S EC and LEL are housed in a 7.4" L x 5.9" W x 4.3" H (188mm x 150mm x 109mm) case with two holes 5.25" (133 mm) from center to center. The RAEGuard^S IR's dimensions vary slightly because of the sensor size: 6.6" L x 5.9" W x 4.3" H (168mm x 150mm x 109mm).

Note: This dimension is 6.6" (168mm) on the RAEGuard^S IR and LEL.

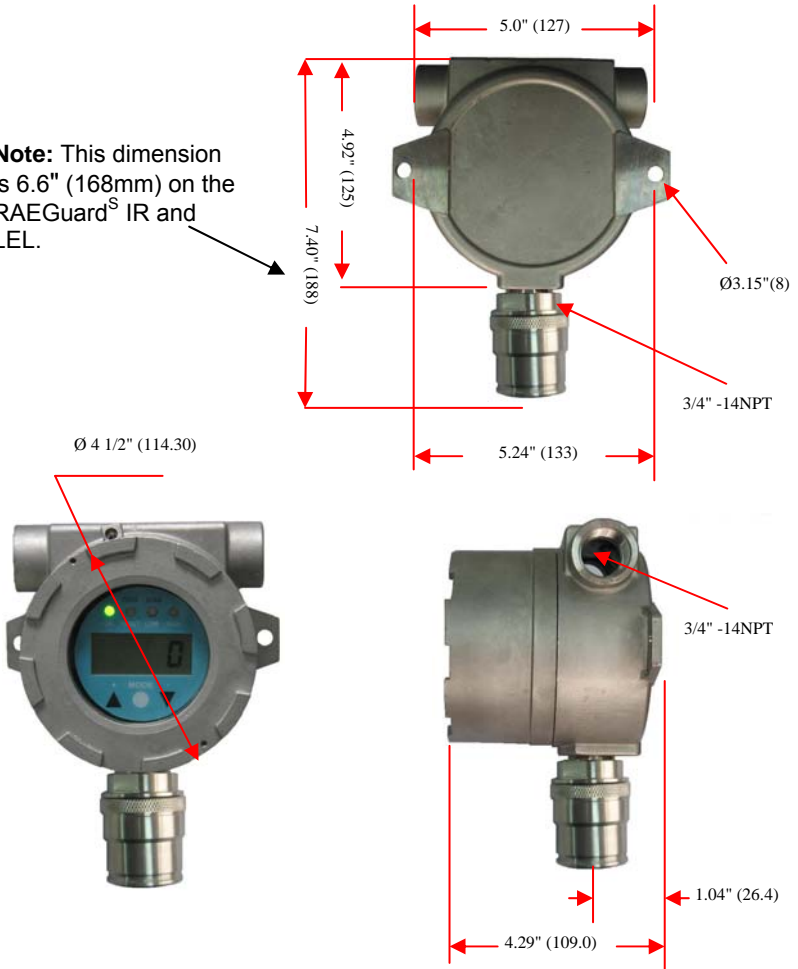

2.2 Installation and Access Instructions

WARNING

1. A minimum of 18" (457mm) of explosion-proof conduit must be used at cable entry in group A and B atmospheres. CSA requires seals in conduit exceeding 5' (1.524 m) in group C atmospheres.
2. To prevent ignition of hazardous atmospheres, area must be free of flammable vapors and supply circuit must be disconnected before removing cover.
3. For European application, the installation must comply with the requirements of EN 60079-14.

Mounting

First, decide where the transmitter will be mounted. (Refer to installation drawing, below.) Drill two holes in mounting surface, with the center of the holes 5.25" (133mm) apart.

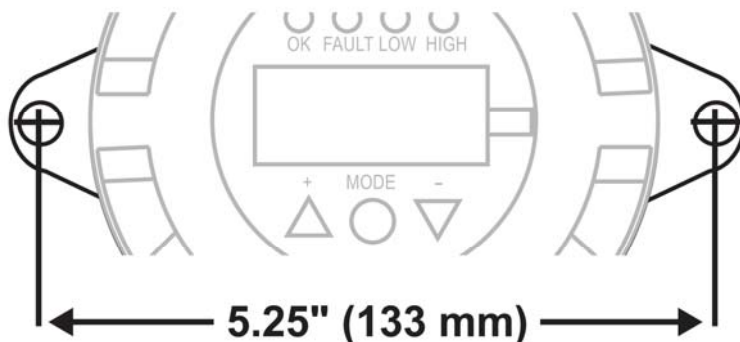

RAEGuard^S EC / LEL / IR User's Guide

Instrument Assembly Removal (EC and LEL)



Prior to service: Make sure power is OFF. Observe all Hazardous Location Safety procedures.



1. Unscrew the housing lid from the housing body by rotating it counter-clockwise. As shipped, one of the conduit holes is covered by the provided hex-head plug. The other conduit is shipped with connected wires.
2. Pull off the retaining clip to release the instrument assembly.



3. Tilt the instrument assembly 90°.
 4. Unlock the black 16-pin connector.
 5. Lift the entire instrument assembly out of the housing.
 6. Unlock the white 8-pin connector.
 7. Remove the sensor.
- Picture shows disassembled instrument

Instrument Assembly Removal (IR)



Prior to service: Make sure power is OFF. Observe all Hazardous Location Safety procedures.



1. Unscrew the housing lid from the housing body by rotating it counter-clockwise. As shipped, one of the conduit holes is covered by the provided hex-head plug. The other conduit is shipped with connected wires.
2. Pull off the retaining clip to release the instrument assembly.



6. Tilt the instrument assembly 90°.
 7. Unlock the 20-pin connector.
 8. Lift the entire instrument assembly out of the housing.
 6. Unlock the 12-pin connector.
 7. Remove the sensor.
- Picture shows disassembled instrument

RAEGuard^S EC / LEL / IR User's Guide

Electrical Wiring

1. Inside the housing bottom, unplug the two green terminal block plugs from the terminal block on the PC boards. **Note:** The terminal block plugs accept 12 AWG to 24 AWG wire.



2. Lace the wires through the RAEGuard^S EC's wire hole(s) and connect wires to the corresponding pin numbers of the terminal blocks:

Terminal	Wire	Pin#
Block 1	Alarm Common (COM)	1
	High/Low Alarm (ALM1)	2
	Fault Alarm (ALM2)	3
	RS485A (485A)	4
	RS485B (485B)	5
Block 2	4-20 mA Output (4-20mA)	6
	Power Supply - Output Common (P-)	7
	Power Supply + (9 to 36VDC) (P+)	8

Instrument Assembly Installation

1. Plug all terminal block plugs into the correct terminal block headers. Keep the extra wires as close to the inside enclosure wall as possible.
2. Screw the sensor module to the housing and plug the 8-pin (EC) or 10-pin (LEL model) or 12-pin (IR model) connector back into its socket.
3. Plug the 16-pin (EC or LEL model) or 20-pin (IR model) connector back into its socket.
4. Pull off the clip to place the instrument assembly back into the housing bottom.
5. Tightly screw the housing top to the housing bottom.

Earth Grounding Instructions

External Earth Grounding

Fasten the crimped ground wire with hardware as illustrated below. The wire should have a minimum cross-section area of 4mm^2 for its conductor.

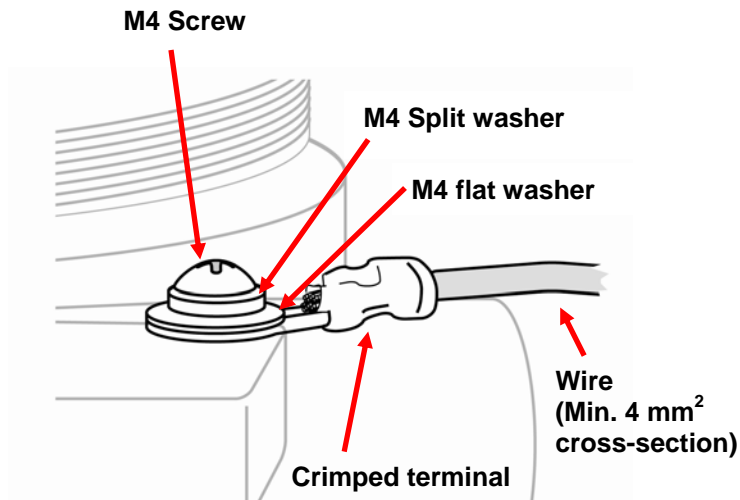

Internal Earth Grounding

Use the same hardware as shown in the illustration of external earth grounding. The wire should be no less than the size of the power lines.

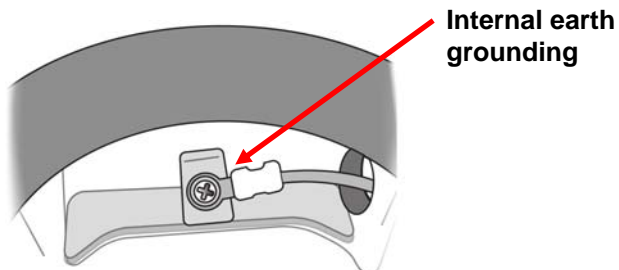

Finished Grounding Wires

Internal and external grounding are shown here, as well as an alternate external grounding point. Always follow local electrical guidelines.

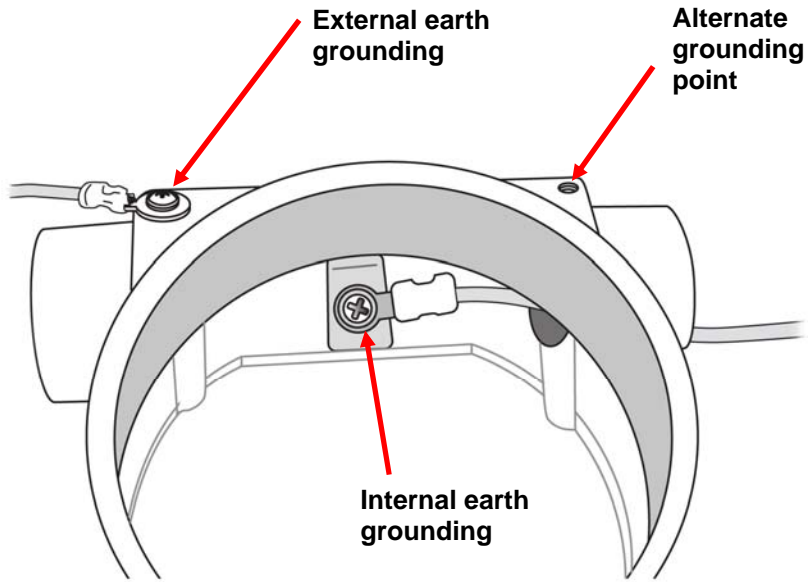

2.3 Display And User Interface

User Interface

The RAEGuard^S EC's user interface consists of four status LEDs, a 4-digit LCD display, and three keys, [+], [MODE], and [-]. The three keys are operated by using the Magnet Key.

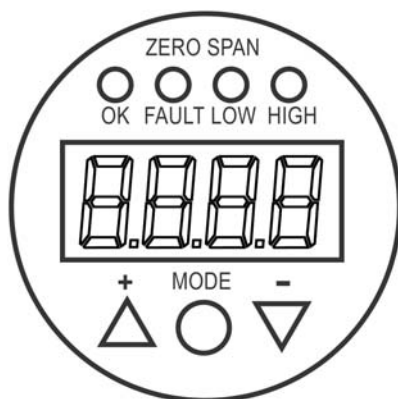

RAEGuard^S EC user interface.

Magnet Key

The RAEGuard^S EC has no external switches, but instead uses the magnetic end of the RAEGuard Magnet Key (p/n 033-2032-000) to activate switches built into the unit.

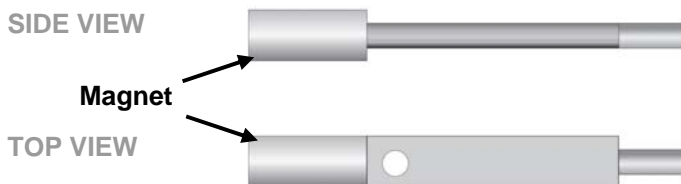

RAEGuard Magnet Key.

RAEGuard^S EC / LEL / IR User's Guide

Using The Magnet Key

Using the magnet end of the Magnet Key, briefly touch the glass above the MODE circle or the triangles labeled [+] and [-]. Then remove the key straight out and away from the RAEGuard^S EC.



RAEGuard Magnet Key touching glass above the [+] triangle.

Important! Never drag the key sideways, or two functions may be activated.

System Initialization

When the RAEGuard^S EC system power is turned on, it initializes and an “InIt” message appears on the display. As the transmitter is warming up, each component is checked, and the LEDs blink all at once. The countdown timer appears on the screen for the warm-up.

RAEGuard^S EC / LEL / IR User's Guide

Reading Display

As the transmitter enters the Reading Display, it automatically starts testing for errors and goes through a cycle of checking each alarm condition. If there are no errors or alarm conditions, the green "OK" LED is lit and the gas concentration is displayed.

If there is an error, the "Fault" LED blinks and an error message blinks. Each alarm condition has a corresponding LED that blinks an amber color when the readings are outside a specified range or limit.

Alarm Contacts

The alarm contacts or alarm relay can be used to drive user-supplied external alarms such as a light or buzzer. The external alarms open in normal conditions and close when an alarm occurs.

Default Alarm Relay Logic

	External Alarm	LED	LCD	Analog Output
Exceeds Low alarm limit	ALM 1 Alarm	Low	reading	Based on reading
Exceeds High alarm limit	ALM 1 Alarm	High	reading	Based on reading
Over Range	ALM 2 Alarm	High	8888	22mA
Calibration fail	ALM 2 Alarm	Fault	Flashing E003	2mA
Sensor drift*	ALM 2 Alarm	Fault	Flashing E004	2mA
ADC saturated *(max)	ALM 2 Alarm	Fault	Flashing E005	2mA

* RAEGuard^S EC and LEL only.

2.4 Calibration

WARNING

The calibration of all newly purchased RAE Systems instruments should be tested by exposing the sensor(s) to a known concentration calibration gas before the instrument is used or put into service. For maximum safety, the accuracy of the RAEGuard^S should be checked by exposing the sensor to a known concentration calibration gas, after a period of time.

The RAEGuard^S is calibrated using a two-point calibration process. First, use a “zero gas.” Then use a “span gas” containing a known concentration of a standard reference gas, to set the second point of reference. **Note:** The zero calibration must be performed before the span calibration.



RAEGuard^S connected to gas cylinder with a calibration adapter.

Gas calibration requires a bottle of zero gas, a bottle of span gas, and a calibration adapter.

RAEGuard^S EC / LEL / IR User's Guide

Zero Calibration

1. Connect the zero gas cylinder to the metal filter gas adapter on the RAEGuard^S transmitter using the provided calibration adapter.
2. To access the Calibration menu, press [MODE] from the Reading Display. Zero calibration appears first, as indicated by the "Zero" message on the screen.

Optional: To advance to span calibration, press [MODE] a second time. "Span" appears on the screen. Skip to Span Calibration instructions on the next page.

Optional: To exit the Calibration menu, press [-] to return to the Reading Display.

3. Turn on the gas flow. Allow gas to flow into the sensor for 30 seconds before zero calibration. Then press [+] to start calibration. The "Zero" LED starts blinking, and the "Zero" message alternates with a countdown timer.

Optional: Before the countdown reaches zero, you may press any key to interrupt zero calibration and advance to span calibration.

4. Once the countdown reaches zero, the "Zero" LED stops blinking, and the zero calibration data is saved.

Note: The transmitter returns to the Reading Display after 60 seconds of idle time.

5. Turn off the zero calibration gas and remove the cylinder.

RAEGuard^S EC / LEL / IR User's Guide

Zero calibration automatically advances to span calibration when complete.

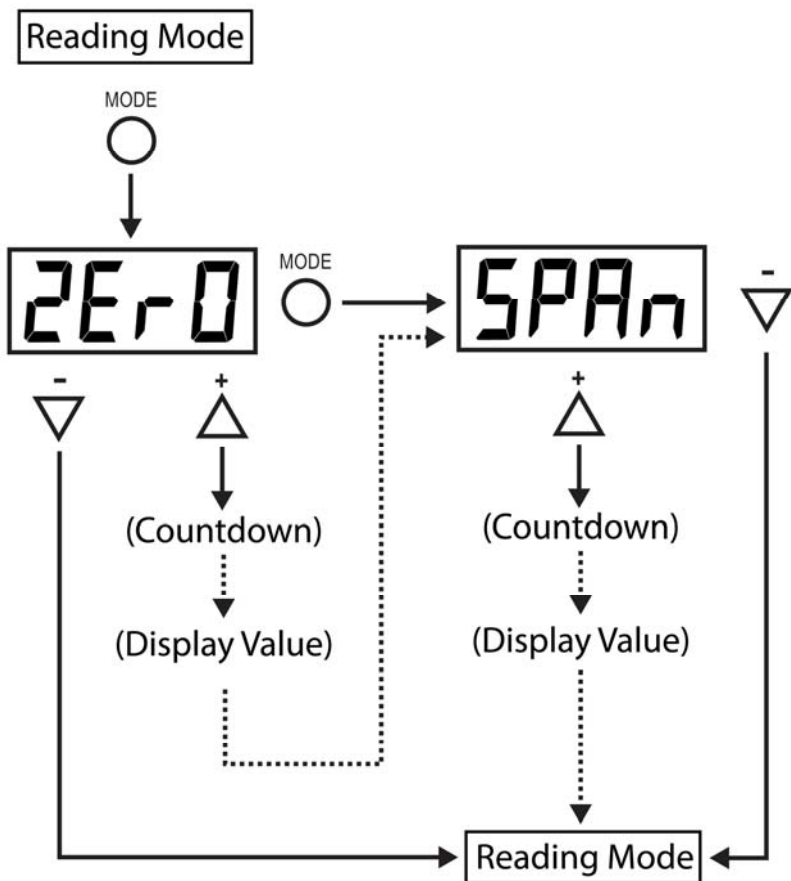

Span Calibration

1. Connect the span gas cylinder to the metal filter gas adapter on the RAEGuard^S transmitter using the provided calibration adapter.

RAEGuard^S EC / LEL / IR User's Guide

Optional: To access span calibration from the Reading Display, press [MODE]. After "Zero" appears on the screen, press [MODE] a second time to advance to span calibration.

Optional: To access span calibration after zero calibration has already started, press any key to advance to span calibration.

Optional: To exit the calibration menu, press [-] to return to the Reading Display.

Note: It is not necessary to exit manually. After 60 seconds of idle time, the RAEGuard^S automatically returns to the Reading Display.

2. Turn on the gas flow. First, let gas flow into the sensor for 30 seconds before span calibration. Then press [+] to start calibration. The "Span" LED starts blinking. The "Span" message alternates with a countdown timer.

Note: Wait for the entire countdown for a complete calibration.

Optional: Before the countdown reaches zero, you may press any key to interrupt span calibration and return to the Reading Display.

3. Once the countdown reaches zero, the "Span" LED stops blinking.
4. If the sensor sensitivity is unacceptable, the screen alternately flashes a "Span" and "FAIL" message until any key is pressed.

Note: If span calibration fails, it may be necessary to replace the sensor.

5. You may choose to press [-] or [MODE] to return to zero calibration and restart the entire calibration process, or press [+] to go to the Reading Display.

RAEGuard^S EC / LEL / IR User's Guide

6. If the sensor's sensitivity is acceptable, the span data is calculated and saved.
7. The calibration procedure is complete. After a few seconds, the transmitter returns to the Reading Display.
8. Turn off span calibration gas and remove the cylinder.

2.5 Advanced Menu (EC & LEL)

The Advanced menu on the RAEGuard^S EC and LEL allows you to change the values for each reading and setup option. To access the Advanced menu from the Reading Display, first press [+], [-], and then [MODE] in sequence. Then scroll through the parameters shown below by pressing [MODE].

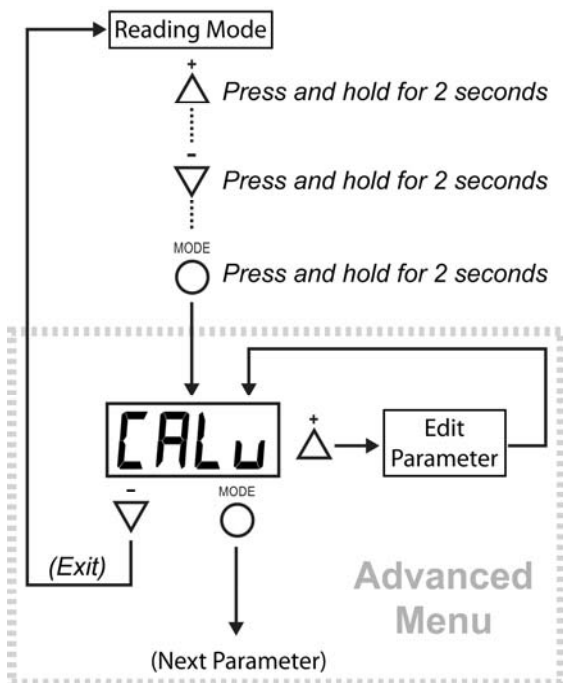

Once you have entered the Advanced Menu, you can edit the parameters for each item in the list.

RAEGuard^S EC / LEL / IR User's Guide

Note: Anytime a submenu screen is idle for more than 60 seconds, the transmitter returns to the Reading Display.

Advanced Menu

Display	Explanation
CALu	Calibration Concentration Value
CF	Correction Factor, only for RAEGuard ^S LEL and IR
LO	Low Alarm
HI	High Alarm
Id	Client ID
bAUd	Baud rate. Supports 19200, 9600, or 4800
LItE	Backlight
Aout	Analog output 4mA and 20mA adjustment
tESt	Test Function of LED, External Alarm, and 4-20mA

- To change a value, press [MODE] until the desired parameter appears.
- Press [+] to enter the Process Menu.
- To increase a value, press [+].
- To decrease a value, press [-].
- When finished changing the value, press [MODE].

If a value has changed, the new value blinks on the LCD.

- Press [-] or [MODE] to discard changes and advance to the next submenu item.
- Press [+] to save changes.

The "SAVE" message appears on the screen to confirm changes have been saved.

RAEGuard^S EC / LEL / IR User's Guide

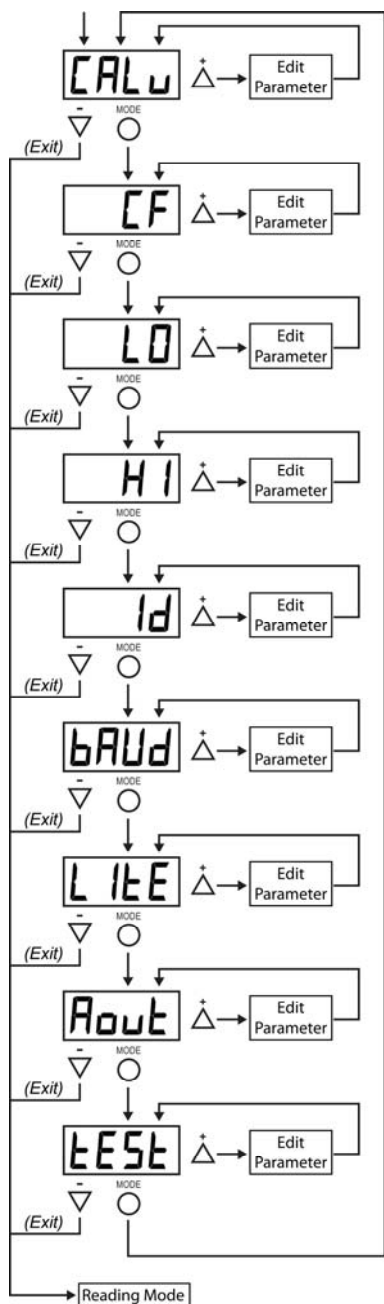

After entering the Advanced Menu, step through the parameters by pressing [MODE]. To edit a parameter, press [+]. The screen shows the current reading value of the parameter.

You can exit Advanced Menu at any screen by pressing [-]. In addition, Advanced Menu is automatically exited if you do not make any changes within 60 seconds.

RAEGuard^S EC / LEL / IR User's Guide

This diagram shows how to edit parameter values and save changes for most of the parameters:

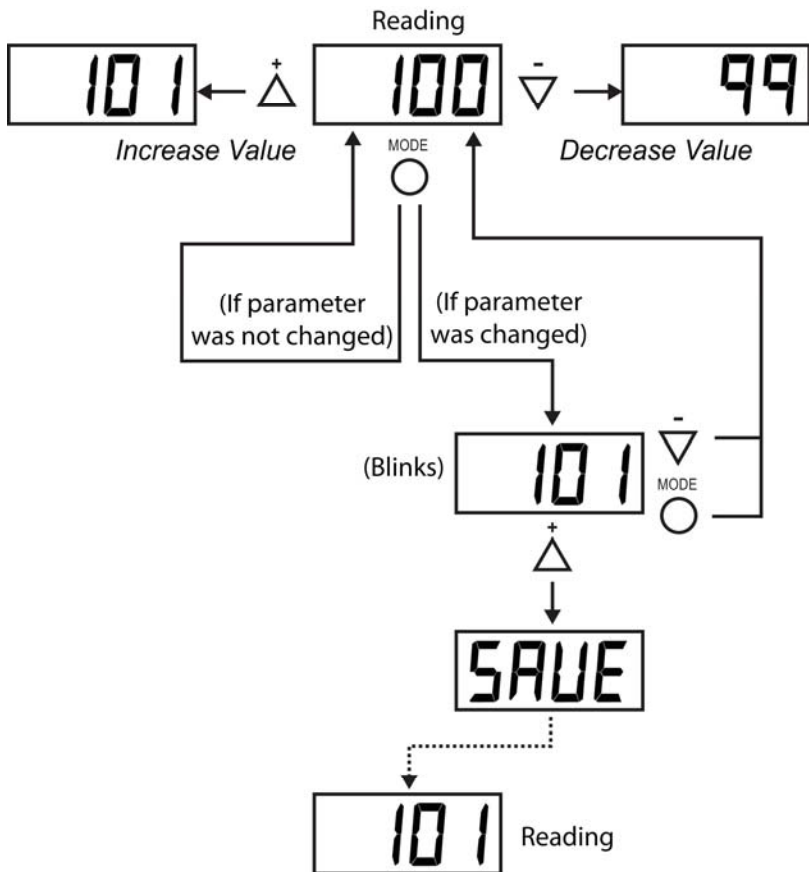

RAEGuard^S EC / LEL / IR User's Guide

This diagram shows the submenu of parameters for the 4-20mA Analog Menu:

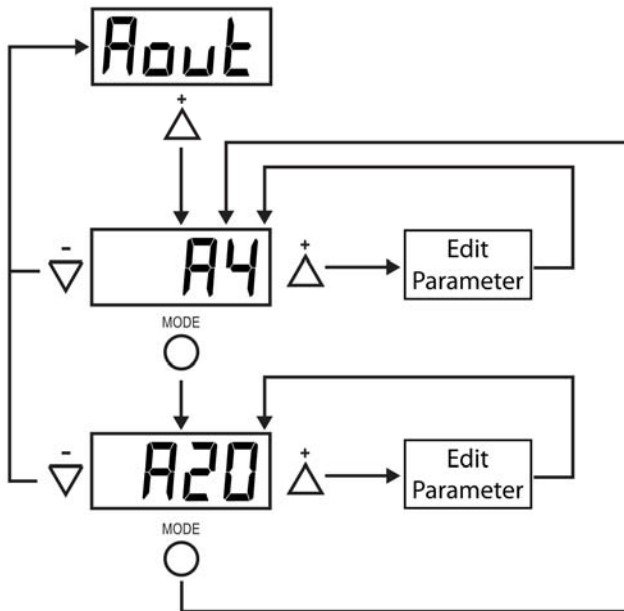

RAEGuard^S EC / LEL / IR User's Guide

This diagram shows the submenu of parameters for the Test Menu:

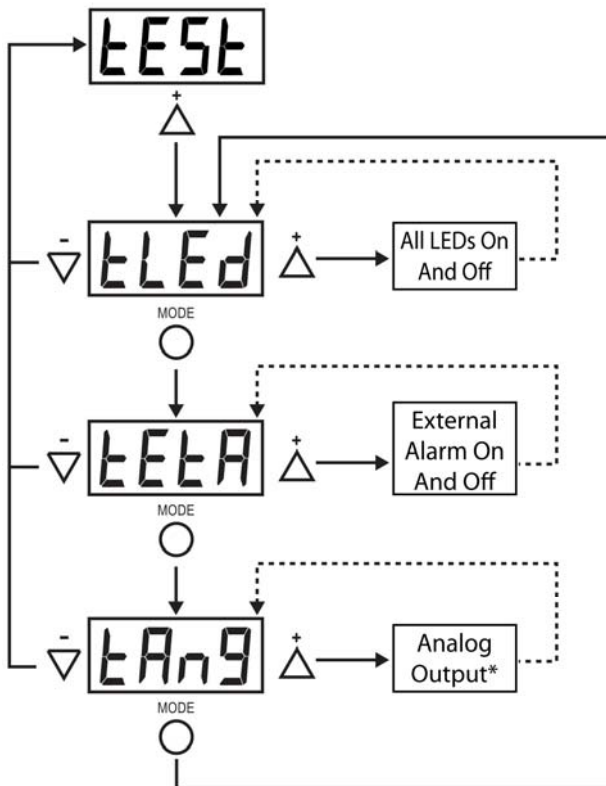

* The analog output steps from 4mA to 20mA in 1mA steps and then steps back down to 4mA before returning to the upper menu. Each step is held for 3 seconds. Press any key to interrupt the process.

2.6 Advanced Menu (IR)

The Advanced menu allows the user to change the values for each reading and setup option. To access the Advanced menu from the Reading Display, first press **[+]**, **[-]**, and then **[MODE]** in sequence. Then scroll through the parameters shown below by pressing **[MODE]**.

Anytime a submenu screen is idle for more than 60 seconds, the transmitter will return to the Reading Display.

Advanced Menu

Submenu	LCD display	Default
Standard gas concentration	CO ₂ : C5E3 (represents 5000 ppm) CH ₄ : C050 (represents 50% LEL)	CO ₂ : C5E3 CH ₄ : C050
Low alarm	CO ₂ : L4E3 (4000 ppm) CH ₄ : L020 (20% LEL)	CO ₂ : L4E3 CH ₄ : L020
High alarm	CO ₂ : H8E3 (8000 ppm) CH ₄ : H050 (50% LEL)	CO ₂ : H8E3 CH ₄ : H050
User ID	IdXX	Id00
Baud-rate (kBaud)	B19.2, B09.6, B04.8 (19200, 9600, and 4800)	B09.6
4mA output adjust	A04	
20mA output adjust	A20	

RAEGuard^S EC / LEL / IR User's Guide

To change a value, press **[MODE]** until the desired parameter appears. Then press **[+]** to enter the Process Menu.

- To increase a value, press **[+]**.
- To decrease a value, press **[-]**.

Press **[MODE]** when finished changing the value. If a value has changed, the new value blinks on the LCD.

- Press **[-]** or **[MODE]** to discard changes and advance to the next submenu item.
- Press **[+]** to save changes. The "SAVE" message appears on the screen to confirm changes have been saved.

2.7 Restoring Default Values (EC & LEL)

You can reset all values in the RAEGuard^S EC and LEL to factory default values. Follow this procedure:

1. Press **[MODE]** to Zero.
2. Press **[MODE]** to SPAN.
3. Press **[MODE]** key to show DEFT in the display.
4. Press **[+]**. The display flashes DEFT and awaits confirmation.
5. Press **[+]** to Save the change. All data is cleared and the default values are now restored.

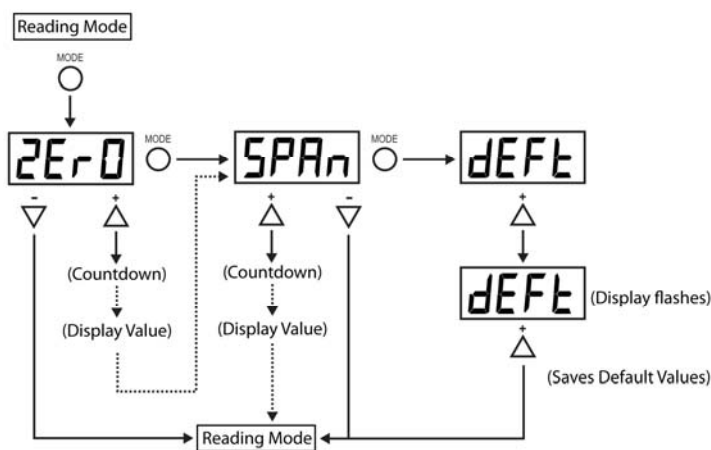

3. Theory of Operation

The **RAEGuard^S EC** uses electrochemical sensors. The electrons generated at the working electrode travel via the contact pins to be measured at the external circuit and are returned to the counter electrode to complete the circuit, The current of the sensor response is proportional to the related EC sensors' gas concentration.

The **RAEGuard^S IR** is based on the patented technology of non-dispersive infrared (NDIR) for hydrocarbon, carbon dioxide and other gas detection. After sample gas diffuses into the infrared optical gas sensor, the electro-magnetic radiation cause oscillation on gas molecules. If this happens the oscillation reduces the amount of radiation, it absorbs a certain degree of radiation. The absorbance at specified wavelength is a measure of the present gas concentration.

The **RAEGuard^S LEL** uses a highly poison-resistant catalytic bead lower explosion limit (LEL) sensor. After sample gas diffuses through the metal sinter into the combustion chamber, a pair of combustion elements inside the combustion chamber burns the combustible gas and generates an electrical signal.

The **RAEGuard^S** is a microcontroller-based instrument. After the electrical signal is conditioned and converted to digital, the microcontroller processes the data, which displays the results locally and reconstructs the digital data into a standard 4-20 mA analog current output signal and RS-485 digital output signal.

The instrument has three magnetic sensing keys. The user may calibrate the transmitter and change the alarm level setting via the magnetic front-panel key pad.

RAEGuard^S EC / LEL / IR User's Guide

The instrument is powered by a DC power supply located in a safe area. The power supply on the PC board contains a switching and linear regulator that converts the main input voltage to 3.3V and 5V DC to power the entire circuit.

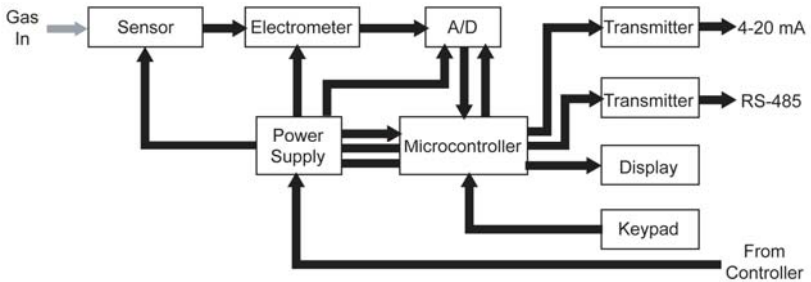

4. Maintenance

As a guide, it is recommended to regularly “bump test” a RAEGuard^S unit with a known percentage gas.

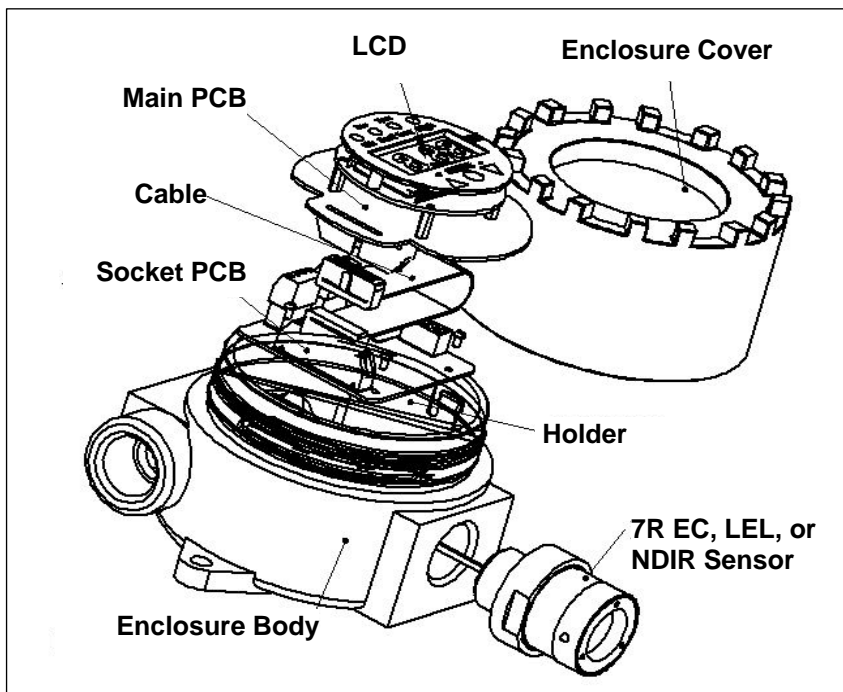

Exploded View of RAEGuard^S EC and LEL Components

Periodically examine the sensor's opening to make sure it is not dirty or covered in dust or debris.

If the sensor requires replacement, refer this unit to qualified service personnel.

5. Troubleshooting

Note: Before diagnosing measurement problems, perform zero and span calibration.

Symptom	Reason & Solution
E001	Reason: Sensor not installed Solution: Install the sensor
E002	Reason: Wrong sensor or Sensor EEPROM error Solution: Replace sensor
E003	Reason: Calibration failure Solution: Make sure of standard gas flow and perform recalibration Replace Sensor
E004	Reason: EC sensor zero drift Solution: Recalibration
E005	Reason: EC sensor exceeds max raw count Solution: Call RAE Systems technical support
E006	Reason: Wire connection error Solution: Check and reconnect wires
E007	Reason: Main PCB EEPROM error Solution: Check and replace main PCB
Couldn't turn on the unit	Reason: Wrong position of one switch (S3) Solution: Check the position of switch S3
Reading abnormally High	Reason: Calibration failure Solution: Recalibration Eliminate/control source of temperature difference
"Span failure" signal	Reason: Sensor broken Solution: Replace Sensor
Low 4-20mA output	Reason: Power supply voltage is lower than specified. Solution: Check power supply voltage and connection.
"Err"	Reason: Sensor ID is creating an error. Solution: Check that the correct sensor is installed. Replace the sensor or update the firmware.

RAEGuard^S EC / LEL / IR User's Guide

Table A: EC Sensor configuration

The following table contains specifications for sensors in the RAEGuard^S EC Series.

Sensors	Range (ppm)	Resolution (ppm)	Response Time (T₉₀)	Span (ppm)	Low (ppm)	High (ppm)
CO	0-1000	1	<30s	50	35	200
H ₂ S	0-300	0.1	<20s	25	10	20
SO ₂	0-150	0.1	<30s	5	2	10
NO	0-1000	0.5	<20s	25	25	50
NO ₂	0-50	0.1	<25s	5	1	10
Cl ₂	0-30	0.1	<30s	10	0.5	5
O ₂	0-30%	0.1%	<20s	20.9%	19.5%	23.5%
ClO ₂	0-1	0.01	<120s	0.5	0.2	0.5
NH ₃	0-100	0.5	<60s	50	25	50
PH ₃	0-20	0.05	<30s	5	1	2
HCN	0-100	0.5	<200s	10	4.7	50
ETO	0-100	0.1	<80s			

6. ModBus/RS-485 Information

Retrieving Gas Concentration Data From A RAEGuard^S Via RS-485

The RAEGuard s communicates by means of MODBUS RTU. All monitors provide a 4-byte register value. **Note:** Gas concentration is the only value that can be retrieved.

As example be low 34 hex = 52 decimal

Overview

This document describes the modbus protocol used in RAEGuard^S products.

1. Communication Setting

Transmission MODE: RTU

Controller: PC or Controller

Client: RAEGuard^S EC, LEL, IR

Baud Rate: 4800, 9600, 19200

Client ID: 1 to 99 (0x0001 to 0x0063), except for 58 (0x3A)

2. Message Frame/Communications Procedure

RAEGuard^S EC/LEL/IR only support Function Code 0x03 (read holding registers), which only supports the "Get Reading Value" from the detector.

RAEGuard^S EC / LEL / IR User's Guide

0x03: Read Holding Registers

Requesting Message:

Device Address	Function Code	Register Address High Byte	Register Address Low Byte	Quantity of Registers High Byte	Quantity of Registers Low Byte	CRC Low Byte	CRC High Byte
Client ID	03	00	08	00	02	CRC	CRC

Answering Message:

Device Address	Function Code	Byte Count	Register Value				CRC Low Byte	CRC High Byte
Client ID	03	04	Reading Highest Byte	Reading Higher Byte	Reading High Byte	Reading Low Byte	CRC	CRC

Note: The length of data from the detector is 4 bytes.

Example:

Request: 01 03 00 09 00 02 14 09
 Answer: 01 03 04 00 00 00 34 FB E4

Note: The maximum distance should be less than 1 km when using a 1.5 mm² cable.



Sicherheit von Kopf bis Fuss



Arsitec AG

Industrie Neuhof 25
3422 Kirchberg BE

fon 034 427 00 58
fax 034 427 00 68

info@arsitec.ch
www.arsitec.ch